

## Galaxy 4000

40/50/65/75 kVA

*Data Center Grade Power  
Protection for Critical  
Environments*



Reliability

Performance

### The Galaxy 4000 . . . *where reliability meets performance*

The Galaxy 4000 separates itself from other UPS modules with technology that increases performance and reliability, all at a competitive cost.

The Galaxy 4000's **IGBT rectifier** significantly minimizes input harmonics and the Power Factor Corrected Input reduces installation costs thanks to smaller cabling and generator costs. Unmatched from a performance standpoint, the Galaxy 4000's unique fault tolerant architecture safely manages output faults without compromising the UPS system. Even common surge currents during output do not result in voltage deviation thanks to the Galaxy 4000's **Digital Power Quality Management** technology.

**Galaxy UPSs are trusted in over 15,000 critical facilities. . .**  
*making it the proven solution*

THE UNINTERRUPTIBLE POWER PROVIDER

### Technical Advantages

- ▶ **IGBT rectifier** virtually eliminates reflected distortion (2% THD from 0% to 100% loads). This avoids polluting the utility power
- ▶ **Transistorized IGBT rectifier** results in fewer parts and higher reliability
- ▶ **Lowest UPS to generator sizing** (1:1)\* saves up to 50% on generator costs
- ▶ **Power Factor Corrected Input** (.99 pf) saves on installation and energy costs
- ▶ **Digital Power Quality Management** (DPQM) provides precision voltage regulation
- ▶ **True on-line double conversion technology** fully isolates and protects against all power quality disturbances
- ▶ **Power surge stabilization system** regulates voltage even under surge conditions common in IT and Industrial environments
- ▶ **Fault tolerant architecture** protects loads and UPS module during unintended faults
- ▶ **Easy and quick to install**
- ▶ **Front only access**
- ▶ **User friendly graphical interface** with optional color touch screen
- ▶ **Web based monitoring and alert\*\*** with unique watchdog technology
- ▶ **SNMP and XML Network Based Power Management\***

\*Based on maximum input current of UPS module

\*\*Optional

**M G E**  
UPS SYSTEMS

## Electrical Specifications

Power (kVA @ 0.8 pf)      40                  50                  65                  75

### Input

Voltage*	208V 3 phase + N + G (± 15%)			
Frequency	60Hz (+8% / -25%)			
Power Factor	<0.98			
Current Distortion (THDI)	<2%			
Input Current (A @ 208 V)	102	127	166	191

### Output

Voltage*	208V ±1%-3 phase + N + G			
Frequency	60Hz (±1-4% selectable) ± 0.1 Hz free running			
Transient Response	±3% for 0% to 100% to 0% load step changes			
Voltage Distortion THD	<1% L-L and L-N for non-linear loads			
Inverter Overload	>120% for 1 min., 145% for 30sec.			
Bypass Overload	10 x nominal current for 1 cycle			
Output Current (A @ 208 V)	111	139	180	208
Heat Rejection (BTUs)	14,900	18,700	24,200	28,000

### Dimensions and Weights

UPS	33.5" W x 72.1" H x 35.6" D, 970 lbs. max			
Battery Cabinet(s)	26.5" W x 72.1" H x 33.5" D, 285/370 battery, 1670 lbs. max			
Battery Cabinet(s)	32.8" W x 72.1" H x 33.5" D, 500 battery, 1670 lbs. max			

### Standards

ISO 9001, UL 1778, cUL, FCC Class A parts, 15 sub part J class A, IEC 1000 level 4, IEEE C62.41-B3, NEC

\* Other voltages available

### Batteries

Power (kVA)                  40                  50                  65                  75

Qty. Cabinets x Watts/Cell	Backup Times (minutes)			
1 x 285 Watts/Cell	12	9	6	
1 x 370 Watts/Cell	20	14	9	8
1 x 500 Watts/Cell	28	22	15	11
2 x 370 Watts/Cell	47	36	25	22
2 x 500 Watts/Cell	67	52	38	31
3 x 500 Watts/Cell	98	85	60	53
4 x 500 Watts/Cell	136	115	85	72

## Galaxy 4000 Schematic

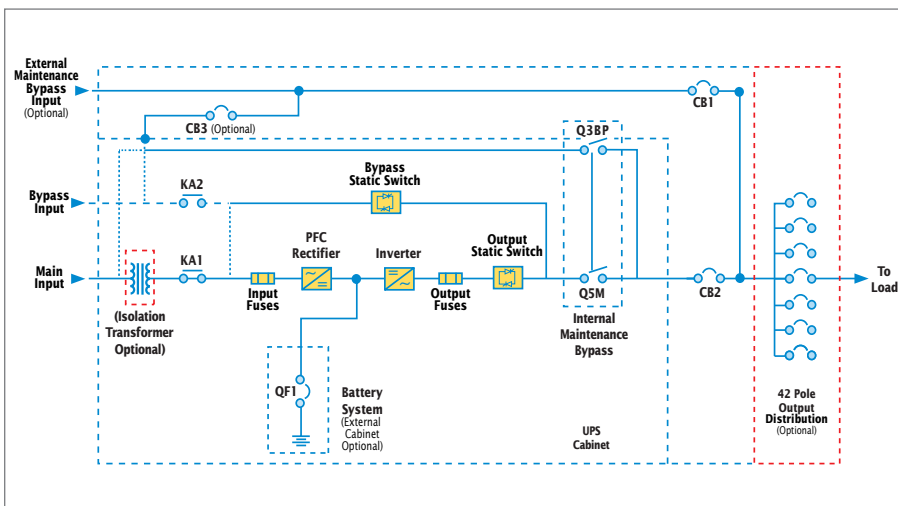

## Standard Features

- ▶ True Double Conversion On-Line topology
- ▶ Input Power Factor Correction (IGBT rectifier)
- ▶ Dual Input
- ▶ Input Distortion Management
- ▶ Digital Power Quality Management System (PWM/IGBT inverter)
- ▶ Step Load Voltage Stabilization
- ▶ Intelligent Battery Management system
- ▶ Fault Tolerant Architecture
- ▶ Casters with stabilizing feet
- ▶ Network based software for multi-server control
- ▶ Dry contact I/O card
- ▶ SNMP manageable
- ▶ Graphic display with multilingual user interface
- ▶ Bottom or top entry
- ▶ Integrated maintenance bypass
- ▶ Four communications ports

## Options

- ▶ 7x24 remote monitoring
- ▶ RS232 / RS485 serial interface
- ▶ Ethernet/SNMP Web Card connection kit
- ▶ External maintenance bypass
- ▶ XML Web card
- ▶ Color LCD touch screen display
- ▶ Seismic

## MGE UPS SYSTEMS

**USA** (headquarters)  
1660 Scenic Avenue  
Costa Mesa, CA 92626  
tel (800) 523-0142  
(714) 557-1636  
fax (714) 557-9788

**CANADA**  
#9, 2798 Thamesgate Dr.  
Mississauga, ON L4T 4E8  
tel (905) 672-0990  
(877) 672-0990  
fax (905) 672-7667

**ARGENTINA**  
Thames 91  
1609 San Isidro  
Prov de Buenos Aires  
tel (54) 11-4766-8777  
fax (54) 11-4766-6008

**BRAZIL**  
Avenida Guido  
Caloi 1985 (GALPAO 23)  
Guarapiranga  
Sao Paulo - SP, CEP 05802  
tel (55) 11-5515-9255  
fax (55) 11-5515-9250

**MEXICO**  
Ave. Congreso de la  
Union  
#524 Colonia Santa Anita  
Mexico D.F 08300  
tel 525 538 9687  
fax 525 530 7625

[www.mgeups.com](http://www.mgeups.com)  
[info@mgeups.com](mailto:info@mgeups.com)

GX 4000  
Revision 104  
Effective: November 2004